

PROJECT
INTERNATIONAL CITY

PROPOSED RESIDENTIAL LAYOUT PLAN OF HOUSES ON THE LOCATION OF L.I.G & E.W.S HOUSING APPROVED EARLIER IN SANCTIONED MAP NOS. 312/01/LO/2014 FOR COMPETENT INFRA HEIGHTS PVT. LTD. & COMPETENT SAI INFRA VENTURE PVT. LTD. & COMPETENT INFRA CITY PVT. LTD. & ALLIED INFRA TOWERS PVT. LTD. & COMPETENT STAR CONSTRUCTIONS PVT. LTD. & MR. RAJESH KUMAR GUPTA S/O SHRI PREM NARAYAN GUPTA, R/O- 17/4, BEHIND S.P.G. HONDA AGENCY STATION ROAD BAREILLY & MR. BIPIN KUMAR S/O SHRI GOPAL, R/O-14, CIVIL LINES BAREILLY & MR. PARESH AGARWAL S/O SHRI NEELESH AGARWAL, & MRS. PRINCY AGARWAL W/O MR. PARESH AGARWAL, R/O- CIVIL LINES PILIBHIT. SITE AT- KHET NO.- 12,13,14,17,19,20,21,24,25(M),39,40,41,42,43,44,45,46,47,48,49, 50,75,76,77,78,79,80,81,82,83,84,118,119,120,121,122,127,128, 129,130,131,132,133,134,135,136,137,138,139,140,146,192,193, 194,195,196,197,198,199,200,202,223,224,225,228,229,259,260, 261,262,263,264,265,266,267,268,273,274,301,302,303,312, 313,346,347,349,350,353,354,355,534,535,536,537,538,539,540, 541,542,581,584. AT VILL.- NARYIAWAL, LUCKNOW ROAD , BAREILLY.

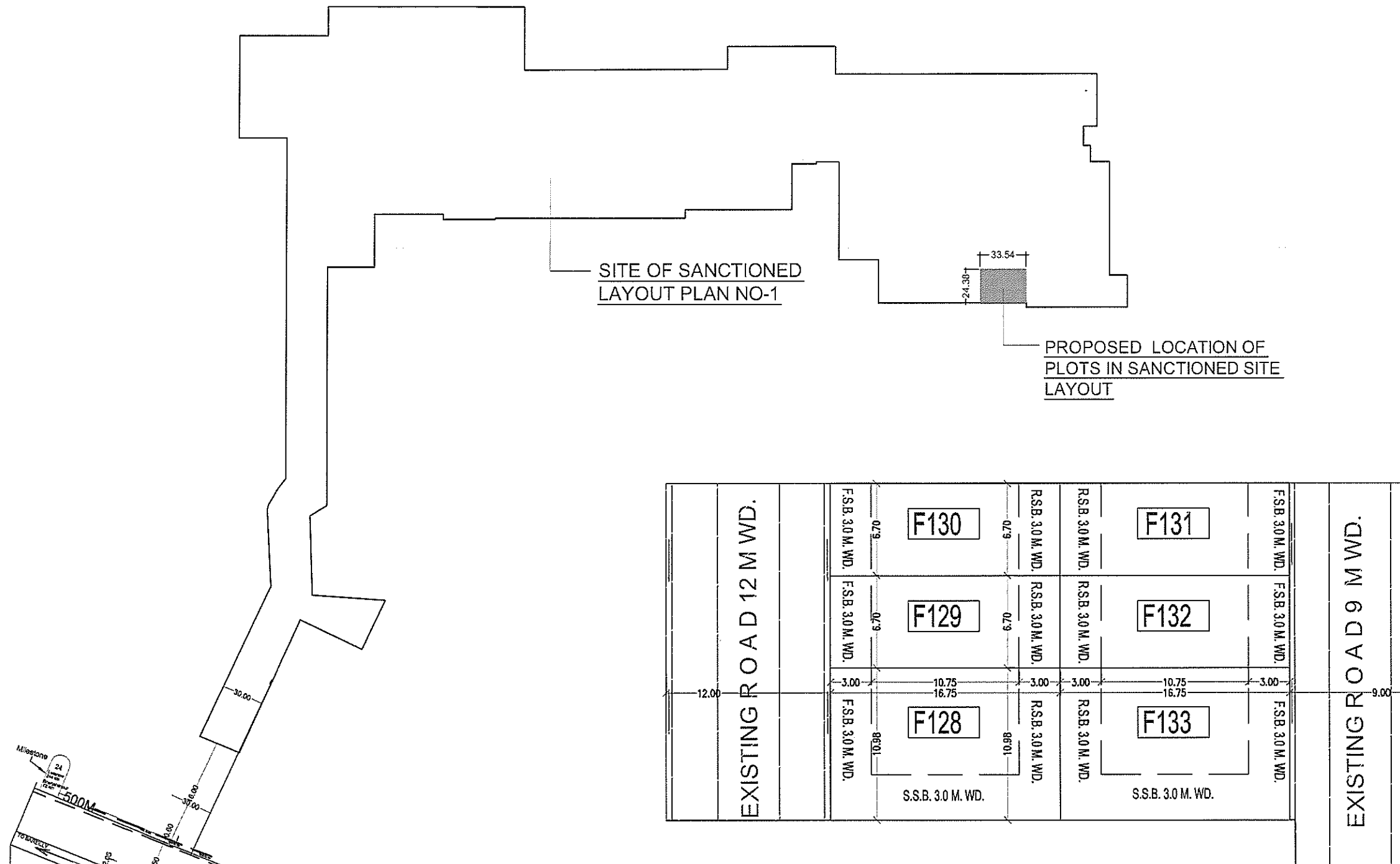

LAND USE- RESIDENTIAL AS PER MASTER PLAN

TOTAL PLOT AREA = 817.71 SQ.M.(0.08hectare)

TYPE F

NAME	SIZE	AREA	NO OF PLOT	G.F. COVD. AREA	F.F. COVD. AREA	MUMTY AREA	TOTAL COVD. AREA	TOTAL PLOT COVD AREA OF ALL UNITS
F128,133	10.98X16.77	184.13	2	82.52 SQ.M.	73.61 SQ.M.	11.24 SQ.M.	167.37SQ.M.	334.74 SQ.M.
F129-F132	6.70X16.77	112.36	4	65.66 SQ.M.	57.72 SQ.M.	9.81 SQ.M.	133.19 SQ.M.	532.76 SQ.M.
TOTAL No. PLOTS			6	TOTAL PLOT COVD. AREA OF ALL UNITS			867.50 SQ.MT.	
TOTAL PLOT AREA OF ALL PLOT			817.71 SQMT					

OWNERS SIGN

For Competent Builders & Developers

Partner

Bipin Kumar

ARCHITECT

SAGUN ARCHITECTS
S-19, FIRST FLOOR JANAKPURI BAREILLY
E-mail - shushishorey2006@gmail.com

PROJECT
INTERNATIONAL CITY

PROPOSED RESIDENTIAL LAYOUT PLAN OF HOUSES ON THE LOCATION OF L.I.G & E.W.S HOUSING APPROVED EARLIER IN SANCTIONED MAP NOS. 312/01A/O/2014 FOR COMPETENT INFRA HEIGHTS PVT. LTD. & COMPETENT SAI INFRA VENTURE PVT. LTD. & COMPETENT INFRA CITY PVT. LTD. & ALLIED INFRA TOWERS PVT. LTD. & COMPETENT STAR CONSTRUCTIONS PVT. LTD. & MR. RAJESH KUMAR GUPTA S/O SHRI PREM NARAYAN GUPTA, R/O- 17^{1/2}, BEHIND S.P.G. HONDA AGENCY STATION ROAD BAREILLY & MR. BIPIN KUMAR S/O SHRI GOPAL, R/O-14, CIVIL LINES BAREILLY & MR. PARESH AGARWAL S/O SHRI NEELESH AGARWAL, & MRS. PRINCY AGARWAL W/O MR. PARESH AGARWAL, R/O- CIVIL LINES PILIBHIT. SITE AT- KHET NO.- 12,13,14,17,19,20,21,24,25(M),39,40,41,42,43,44,45,46,47,48,49, 50,75,76,77,78,79,80,81,82,83,84,118,119,120,121,122,127,128, 129,130,131,132,133,134,135,136,137,138,139,140,146,192,193, 194,195,196,197,198,199,200,202,223,224,225,226,229,259,260, 261,262,263,264,265,266,267,268,273,274,301,302,303,312, 313,346,347,349,350,353,354,355,534,535,536,537,538,539,540, 541,542,581,584, AT VILL.- NARYIAWAL, LUCKNOW ROAD , BAREILLY.

TYPE F

TOTAL PLOT AREA = 184.13 SQMT
GROUND FLOOR COVD. AREA = 82.52 SQMT
FIRST FLOOR COVD. AREA = 73.61 SQMT
MUMTY AREA = 11.24 SQMT
TOTAL COVD. AREA = 167.37 SQMT
ALLOWED GROUND COVERAGE = 65% (119.68sqmt)
ACHIEVED GROUND COVERAGE = 44.81% (82.52sqmt)
ALLOWED F.A.R. = 1.75 (322.23sqmt)
ACHIEVED F.A.R. = 0.85 (156.13 sqmt)

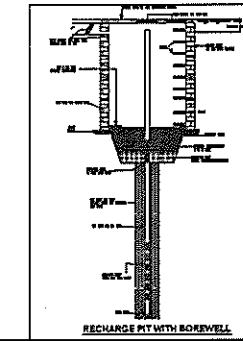

RECHARGE STRUCTURE PROPOSED
RAIN WATER FROM THE ROOF WILL BE DRAIN THROUGH VERTICAL RAIN WATER PIPES AND DISCHARGE THROUGH EXTERNAL STORM WATER DRAIN TO THE PROPOSED RECHARGE PIT / CHAMBER FOR RAIN WATER HARVESTING / RECHARGING. THE RE-CHARGE CHAMBER SHALL HAVE BORDING OF 200 MM DIA. TILED FITH GRAVELS AND A DEPTH UP TO 300MM. BELOW GROUND LEVEL. THE ABOVE BORDING WILL HAVE HOLES OF 100 MM DIA. WITH FILTER AT REGULAR INTERVAL TO RECHARGE THE RAIN WATER IN TO THE SUB SURFACE AQUIFER. FILTER MEDIA AS PER REQUIREMENTS IS PROVIDED TO ENSURE THE FILTERED WATER DISCHARGE INTO THE AQUIFER. THE ABOVE RE-CHARGE CHAMBERS WILL HAVE A PRE-CAST REINFORCEMENT COVERS FOR MAINTENANCE PURPOSES. EXPECTED LIFE OF THE ABOVE SCHEME - 10 YEARS

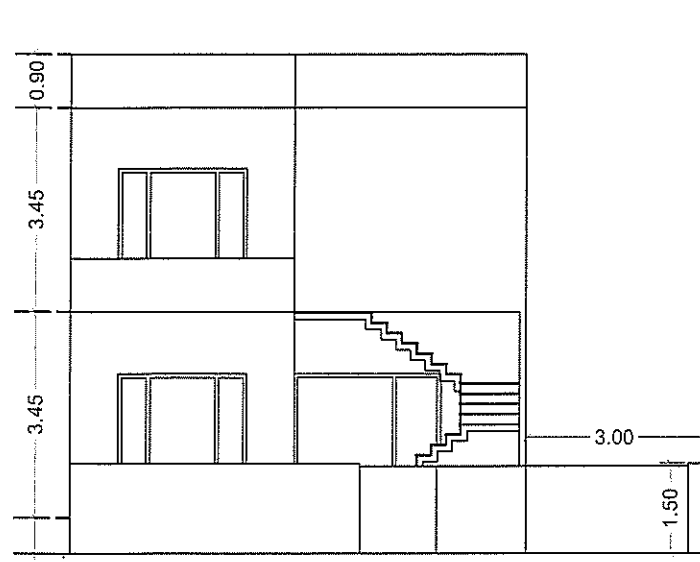

FRONT ELEVATION
SCALE 1:100

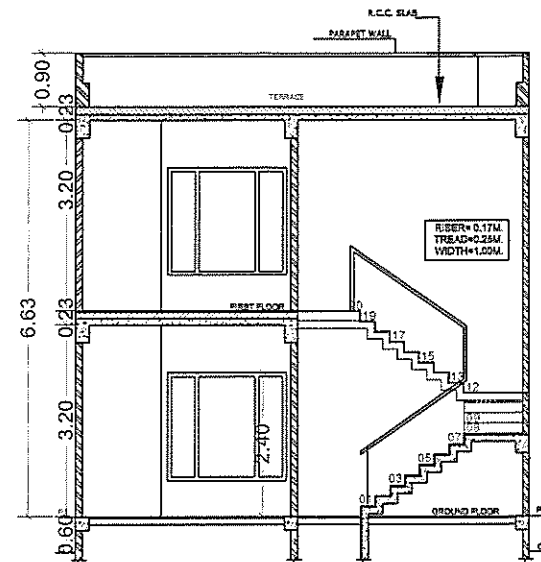

SECTION AT A-A
SCALE 1:100

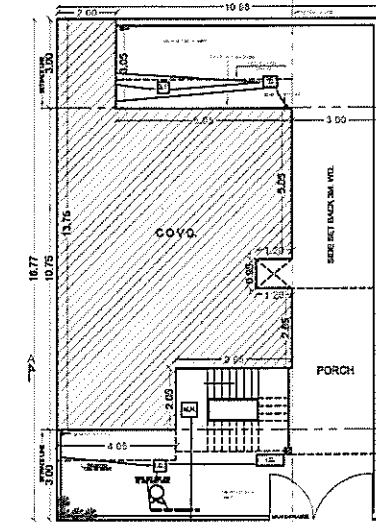

SITE PLAN
SCALE 1:200

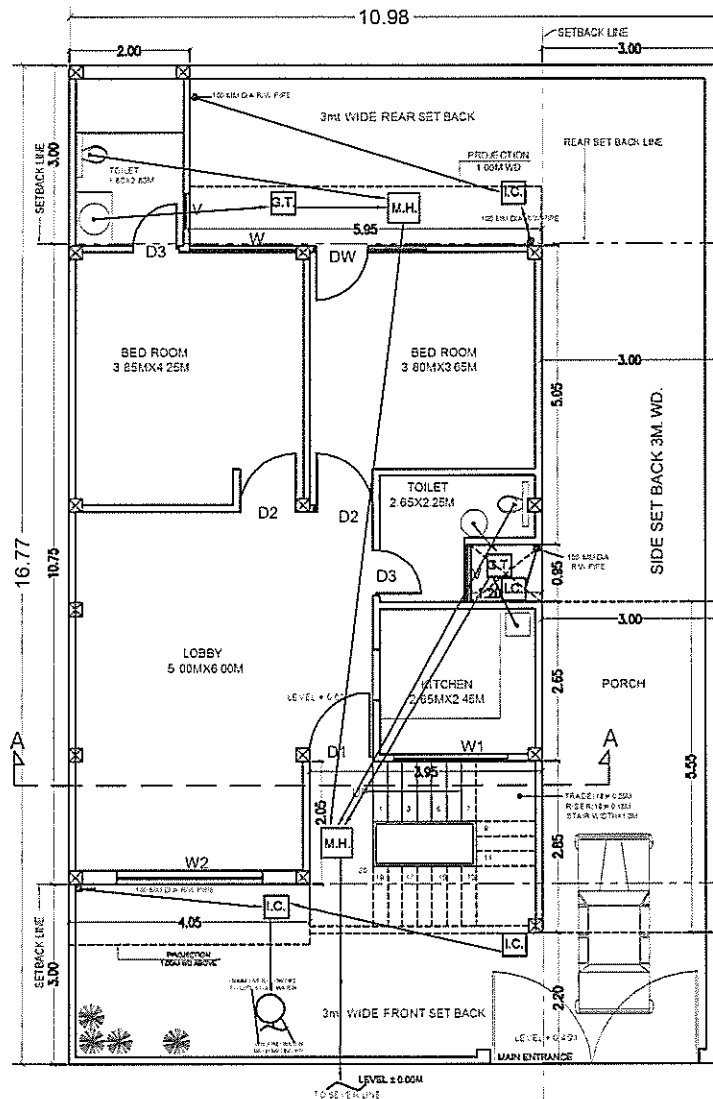

GROUND FLOOR PLAN
SCALE 1:100

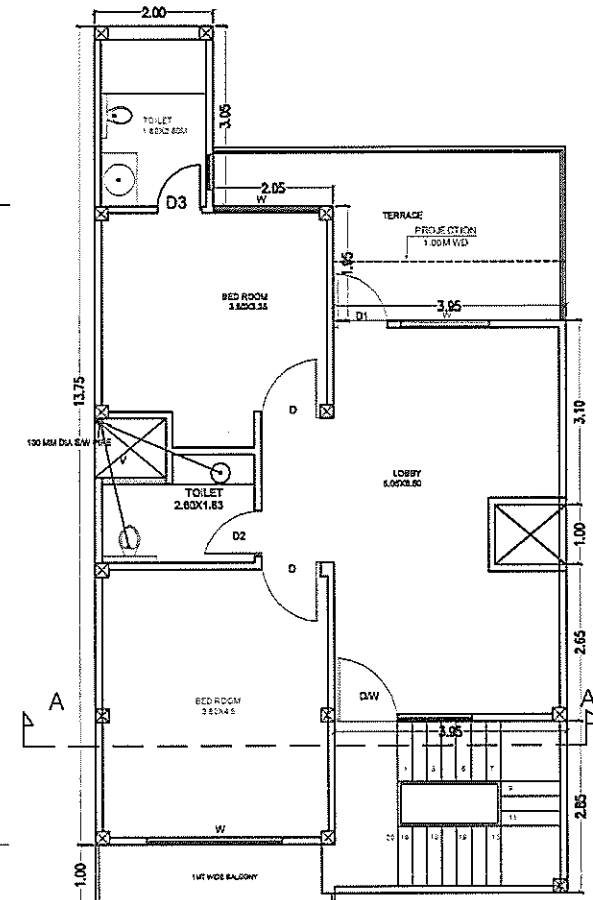

FIRST FLOOR PLAN
SCALE 1:100

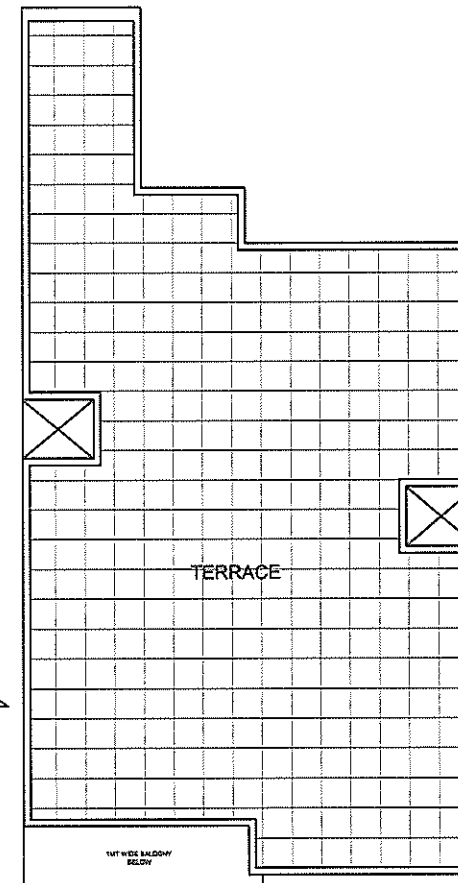

TERRACE FLOOR PLAN
SCALE 1:100

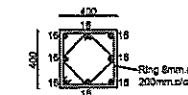

TYPICAL DETAIL OF COLUMN C1 (400x400)

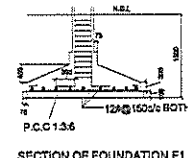

SECTION OF FOUNDATION F1

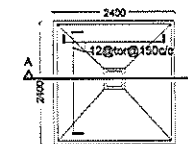

PLAN OF FOUNDATION F1

DETAIL OF FOUNDATION & COLUMN SCALE=N.T.S

TYPICAL FLOOR PLAN FOR UNITS NO. F-128 , F-133

OWNERS SIGN
For Competent Builders & Developers
[Signature]
Partner **Bipin Kumar**

ARCHITECT *[Signature]*
SAGUN
ARCHITECTS & INTERIOR DESIGNERS
S-19, FIRST FLOOR JANAKPURI BAREILLY
E-mail - sagunarchitects@gmail.com

TYPE F

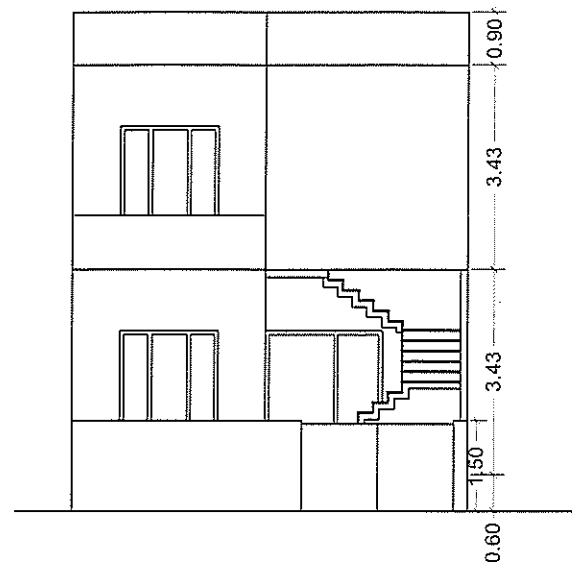

FRONT ELEVATION
SCALE 1:100

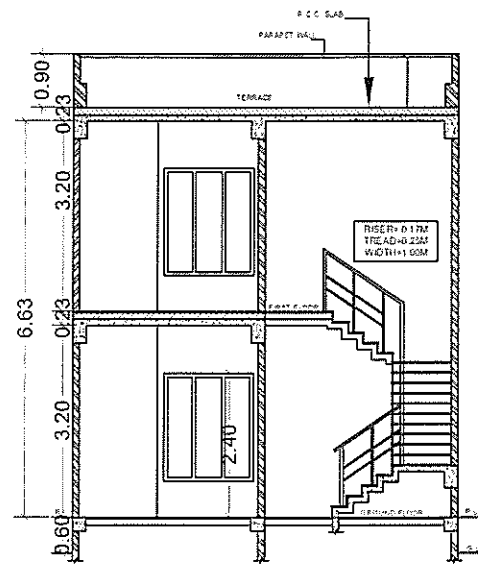

SECTION AT A-A
SCALE 1:100

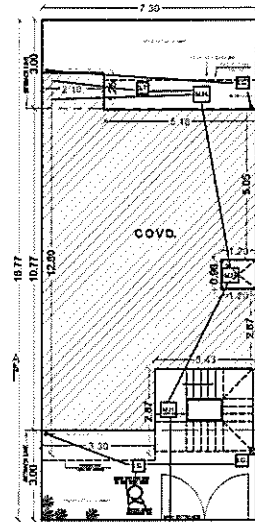

SITE PLAN
SCALE 1:200

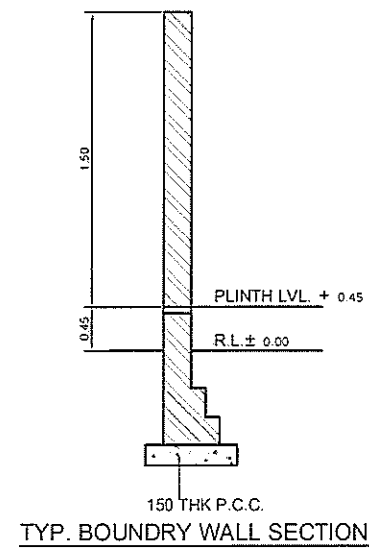

TYP. BOUNDARY WALL SECTION

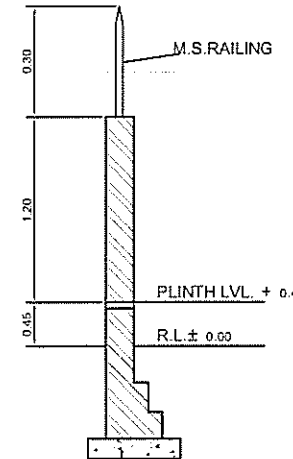

TYP. BOUNDARY WALL SECTION

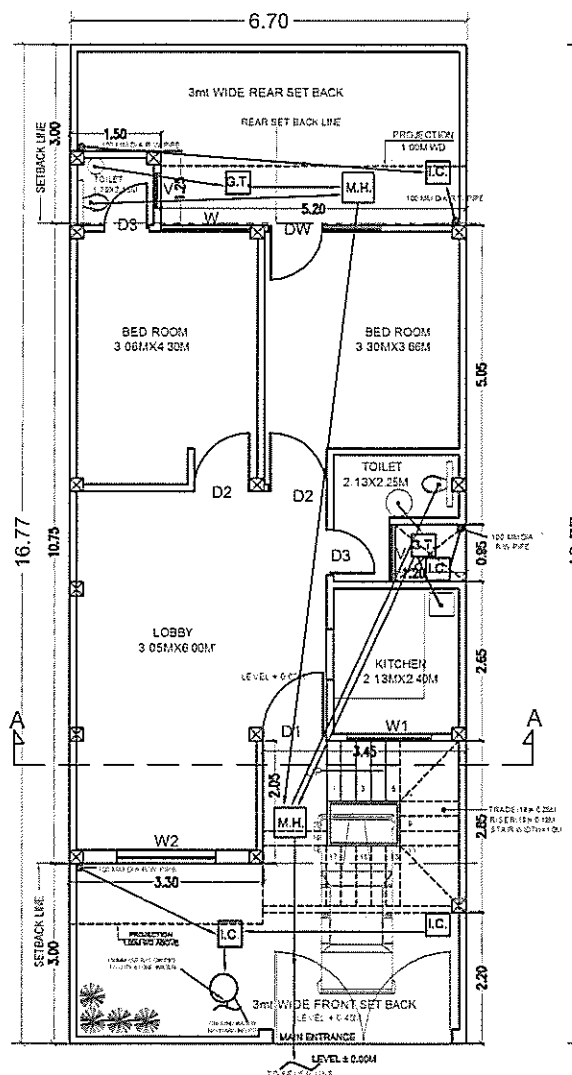

GROUND FLOOR PLAN
SCALE 1:100

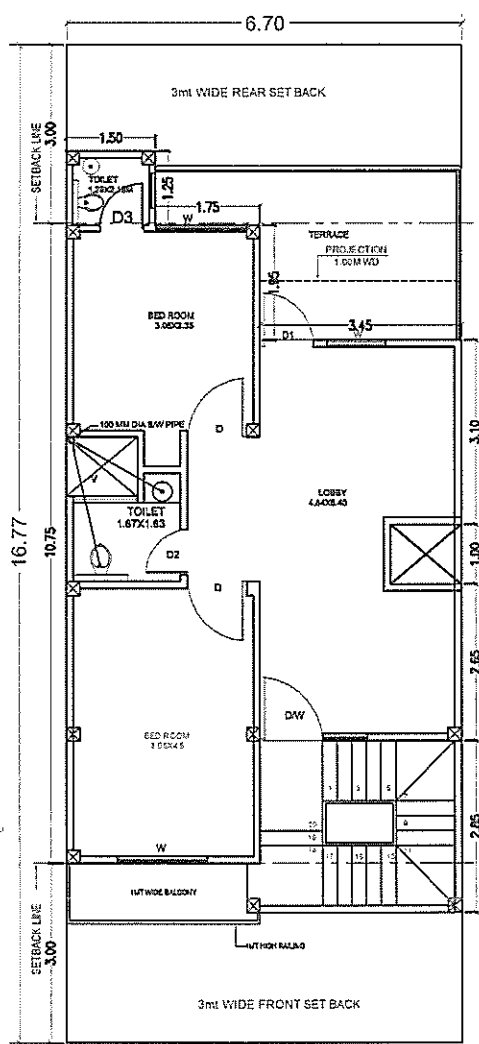

FIRST FLOOR PLAN
SCALE 1:100

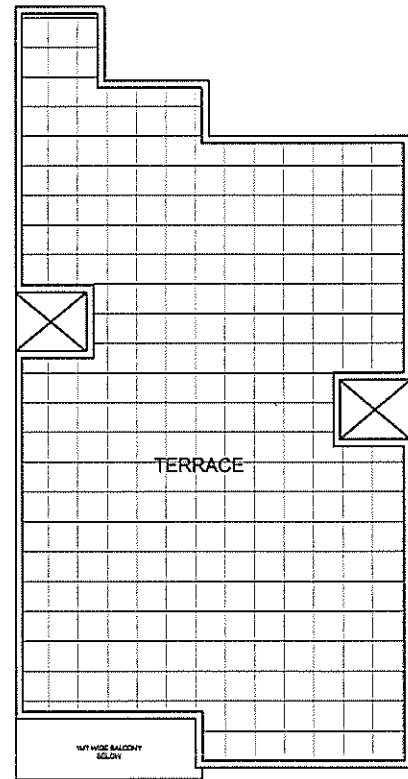

TERRACE FLOOR PLAN
SCALE 1:100

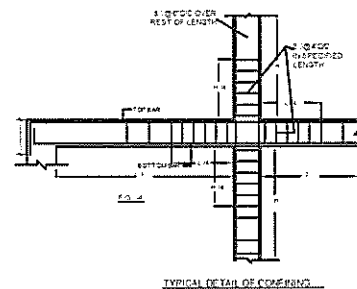

TYPICAL DETAIL OF COVERING

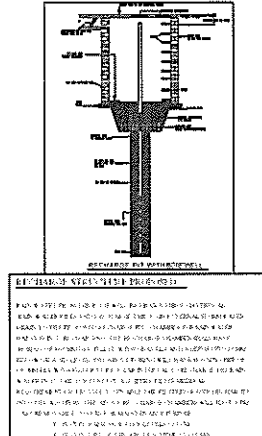

SECTION OF FOUNDATION F1

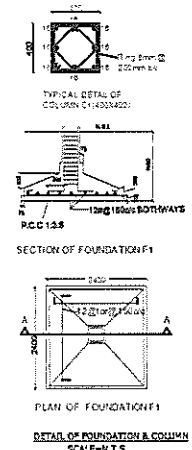

PLAN OF FOUNDATION F1

PROJECT
INTERNATIONAL CITY

PROPOSED RESIDENTIAL LAYOUT PLAN OF HOUSES ON THE LOCATION OF L.I.G & E.W.S HOUSING APPROVED EARLIER IN SANCTIONED MAP NOS. 312/01/LO/2014 FOR COMPETENT INFRA HEIGHTS PVT. LTD. & COMPETENT SAI INFRA VENTURE PVT. LTD. & COMPETENT INFRA CITY PVT. LTD. & ALLIED INFRA TOWERS PVT. LTD. & COMPETENT STAR CONSTRUCTIONS PVT. LTD. & MR. RAJESH KUMAR GUPTA S/O SHRI PREM NARAYAN GUPTA, R/O- 17/4, BEHIND S.P.G. HONDA AGENCY STATION ROAD BAREILLY & MR. BIPIN KUMAR S/O SHRI GOPAL, R/O-14, CIVIL LINES BAREILLY & MR. PARESH AGARWAL S/O SHRI NEELESH AGARWAL, & MRS. PRINCY AGARWAL W/O MR. PARESH AGARWAL, R/O- CIVIL LINES PILIBHIT. SITE AT- KHET NO- 12,13,14,17,19,20,21,24,25(M),39,40,41,42,43,44,45,46,47,48,49, 50,75,76,77,78,79,80,81,82,83,84,118,119,120,121,122,127,128, 129,130,131,132,133,134,135,136,137,138,139,140,146,192,193, 194,195,196,197,198,199,200,202,223,224,225,228,229,269,260, 261,262,263,264,265,266,267,268,273,274,301,302,303,312, 313,346,347,349,350,353,354,355,534,535,536,537,538,539,540, 541,542,581,584, AT VILL - NARYIAWAL, LUCKNOW ROAD , BAREILLY.

TYPE F

TOTAL PLOT AREA	= 112.36 SQMT
GROUND FLOOR COVD. AREA	= 65.66 SQMT
FIRST FLOOR COVD. AREA	= 57.72 SQMT
MUMTY AREA	= 9.81 SQMT
TOTAL COVD. AREA	= 133.19 SQMT
ALLOWED GROUND COVERAGE	= 65% (73.03sqmt)
ACHIEVED GROUND COVERAGE	= 58.44% (65.66sqmt)
ALLOWED F.A.R.	= 1.75 (196.63sqmt)
ACHIEVED F.A.R.	= 1.10 (123.38sqmt)

TYPE	SIZE	SILL	LINTEL
D1	1.00X2.10	--	2.10
D2	1.00X2.10	--	2.10
D3	0.75X2.10	--	2.10
D/W	1.97X2.10	0.45	2.10
W	2.45X1.50	0.45	2.10
V	0.91X1.50	1.06	2.10

TYPICAL FLOOR PLAN FOR UNITS NO. F-129 TO F-132

OWNERS SIGN

For Competent Builders & Developers

Partner *Bipin Kumar* Bipin Kumar

ARCHITECT

Sagun
SAGUN ARCHITECTS

ARCHITECTS & INTERIOR DESIGNERS
S-19, FIRST FLOOR JANAKPURI BAREILLY
E-mail - sagunarchitects@gmail.com

TYPE F